

PART NO.	DESCRIPTION	QTY.	PART NO.	DESCRIPTION	QTY.
12497	CONTACT PLATE, CHR	4	27601	INSERT, THREADED, METRIC, 6MM	18
12506	ADHESIVE, TRANSFER TAPE, 5 MIL	4	27602	INSERT, THREADED, METRIC, 8MM	6
22016	SCREW, .375-16X2.50, HEX HD CAP	3	27605	M10 x 1.50 x 30, HEX HEAD CAP	4
22027	WASHER, SPLIT LOCK, .250	8	27612	SCREW, M3 x 0.5 x 10, SELF TAPPING, PAN HEAD TORX	6
22037	SCREW, SET, 0.25-20x0.375	2	27631	HOUSING, ERGO-BAR, LEFT UPPER	1
22077	.375, NUT, HEX	2	27632	HOUSING, ERGO-BAR, LEFT LOWER	1
22845	WASHER, 1 1/4X 17/32	4	27633	HOUSING, ERGO-BAR, RIGHT UPPER	1
23729	WASHER, SPLIT LOCK 3/8	3	27634	HOUSING, ERGO-BAR, RIGHT LOWER	1
25562	FLYWHEEL, CLUBTRAK	1	27640	BELT, WALKING	1
27068	BRACKET, ACTUATOR	1	27641	WIRE HARNESS, CONTACT HEART RATE	1
27069	ASSEMBLY, BRACKET, ACTUATOR	1	27646	MACHINED EXTRUSION RIGHT HAND	1
27300	FELT, ADHESIVE-BACKED	4	27647	MACHINED EXTRUSION, LEFT HAND	1
27378	WASHER, M6, FLAT, STAINLESS	4	27648	ASSY, ENDCAP, SIDERAIL, LEFT	1
27379	M8 x 1.25 x 16, BUTTON HEAD	10	27649	ASSY, ENDCAP, SIDERAIL, RIGHT	1
27386	ASSY, CABLE, C50 ERGOBAR	1	27650	WELDMENT, REAR FRAME SUPPORT	1
27410	PLATE, MOTOR MOUNTING	1	27654	LEVELING PAD (.500-13UNC-2A X 1.88 BASE)	2
27415	PLUG, HOLE, RIB-LOCK	2	27660	ASSEMBLY, UPRIGHT SUPPORT, RH	1
27417	ROLLER ASSEMBLY, DRIVE	1	27664	KEY PANEL, ERGO-BAR	1
27424	BLOCK, GRADE NUT	1	27665	PCBA, ERGO-BAR	1
27425	SUPPORT, GRADE WELDMENT, MACHINED	2	27666	GRILL, FRONT COVER	1
27426	ASSY, NUTPLATE, FOOT	2	27675	ASSEMBLY, RETAINER, FRONT ROLLER SHAFT	2
27430	BRACKET ASSEMBLY, TENSIONER	1	27676	SPACER, SOFT DECK	2
27436	GUARD, FOOT	1	27677	SIDERAIL, STIFFNER ASSEMBLY, LH	1
27441	WASHER, SHOULDER ISOLATION	4	27678	SIDERAIL, STIFFNER ASSEMBLY, RH	1
27443	BUSHING, SPANNER	2	27679	ASSEMBLY, UPRIGHT SUPPORT, LH	1
27444	BUSHING, SHOULDER	2	27680	HOUSING, ERGO-BAR, MID UPPER	1
27458	DRIVE BELY, POLY-V	1	27681	HOUSING, ERGO-BAR, MID LOWER	1
27467	PULLEY ASSEMBLY, REAR	1	27682	LOGO, STAIRMASTER	1
27469	RETAINER, COVER	14	27684	WELDMENT, CONTROLLER SUPPORT	1
27477	HOOD	1	27689	STEEL HEADFRAME ASSEMBLY	1
27478	COVER, TRIM, FRONT	1	27764	SCREW, THREAD FORMING #6-32 X .375	4
27485	WELDMENT, GRADE	1	27951	ASSY, CABLE, LOWER C50 COMM.	1
27487	DRIVE MOTOR, AC VARIABLE	1	27952	ASSY, CABLE, UPPER, C50 COMM	1
27488	ASSY, VSD	1	28390	END CAP, ROUND, 2"	2
27489	PLUG, HOLE, SHEET METAL, 1.50	2	36209	INSERT, THREADED, METRIC, 6MM	4
27490	WELDMENT, UPRIGHT	1			
27535	BED, SLIDER, 612/2100	1			
27536	EXTRUSION, SIDEWALL COVER	2			
27537	M3 X .50 X 12 SCREW, SEM, PHP, EXT STAR	12			
27540	WASHER, M3, FLAT, ZINC PLATED	6			
27541	BUSHING, BRONZE	2			
27542	M6 x 1.0 x 16, BUTTON HEAD	10			
27543	COMPRESSION MOUNT, LONG	10			
27544	COMPRESSION MOUNT, DECK	8			
27551	WHEEL, POLYOEFIN	2			
27552	ROTARY TENSIONER	1			
27556	BUSHING, GRADE ADJUST	2			
27559	M8 x 1.25 x 70, BUTTON HEAD	8			
27561	M8 x 1.25 HEX NUT	6			
27562	WASHER, .490 x 1.063 x .093, NEOPRENE	8			
27563	M8 x 1.25 x 60, HEX HEAD CAP	8			
27564	WASHER, M8, FLAT, FENDER, ZINC PLATED	12			
27565	WASHER, M6, FLAT, BLACK OXIDE	2			
27566	WASHER, M6, SPLIT LOCK, BLACK	2			
27567	M6 x 1.0 x 16, BUTTON HEAD, BLACK	2			
27568	WASHER, M8, FLAT, BLACK OXIDE	2			
27569	M8 x 1.25 x 90, HEX HEAD CAP, BLACK	2			
27570	CLAMP, VSD BOARD	1			
27571	PAD, VSD CLAMP	1			
27573	NUT, M5 X 0.8, HEX	2			
27574	M5 x 0.80 x 50, HEX HEAD CAP	2			
27575	WASHER, M6, FLAT, WIDE, ZINC PLATED	16			
27576	M6 x 1.00 x 35, HEX HEAD CAP	14			
27577	M6 x 1.00 x 16, HEX HEAD CAP	4			
27578	WASHER, M6, SPLIT LOCK	6			
27579	WASHER, M6, FLAT, ZINC PLATED	2			
27582	RIVET, .1875 DIA. X .375 GRIP, BLACK	14			
27583	GUIDE, WIRE .500	4			
27584	GUIDE, WIRE .375	6			
27585	WASHER, .406X1.25X.047, STEEL, ZINC	5			
27586	SPACER, NYLON	4			
27587	WASHER, M10, FLAT, ZINC PLATED	4			
27588	WASHER, M10, SPLIT LOCK	4			
27590	M8 x 1.25 x 20, HEX HEAD CAP	28			
27591	WASHER, M8, FLAT, ZINC PLATED	58			
27592	WASHER, M8, SPLIT LOCK	64			
27593	M8 x 1.25 x 25, HEX HEAD CAP	10			
27594	.25-20 X .75, THREAD CUTTING, HEX WASHER HEAD	8			
27595	ASSY, CONFIG CABLE	1			

REVISIONS			
REV.	DESCRIPTION	DATE	DRAFTER
A	RELEASED FOR PRODUCTION PER ECO XXXX	MM/DD/YEAR	DRAFTER

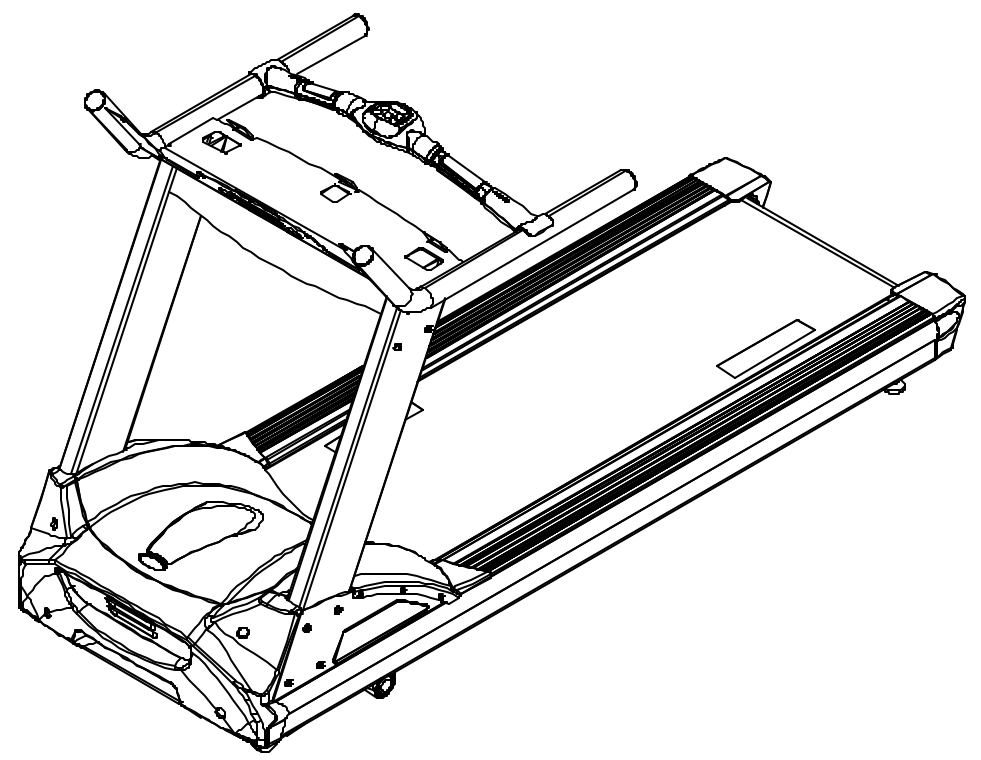

UNLESS OTHERWISE SPECIFIED: 1. ALL DIMENSIONS APPLY BEFORE PLATING OR COATING. 2. REMOVE ALL BURRS, BREAK SHARP EDGES .020 MAX 3. ALL DIMENSIONS ARE IN INCHES. 4. ALL VIEWS THIRD ANGLE PROJECTION.	TOLERANCES ANGLES: BENT ±.2° MACHINED ±.0030 .XX ±.0010 .XXX ±.0010		THE NAUTILUS GROUP TITLE: MECHANICAL ASSY, 2100, TREADMILL
	MATERIAL: N/A FINISH: N/A		
CONFIDENTIAL AND PROPRIETARY THIS DOCUMENT IS THE PROPERTY OF THE NAUTILUS GROUP. IT MAY NOT BE REPRODUCED IN WHOLE OR PART, PROVIDED TO THIRD PARTIES, OR USED FOR ANY PURPOSE OTHER THAN THE PERFORMANCE OF WORK FOR THE NAUTILUS GROUP, WITHOUT WRITTEN AUTHORIZATION. ALL RIGHTS ARE RESERVED, INCLUDING COPYRIGHTS.			SIZE: D DWG. NO.: 27671 VER: REV:
SOLIDWORKS MODEL FILE: 27671			SCALE: 1:1 PLOT DATE: 8/6/2003 SHEET 1 OF 7

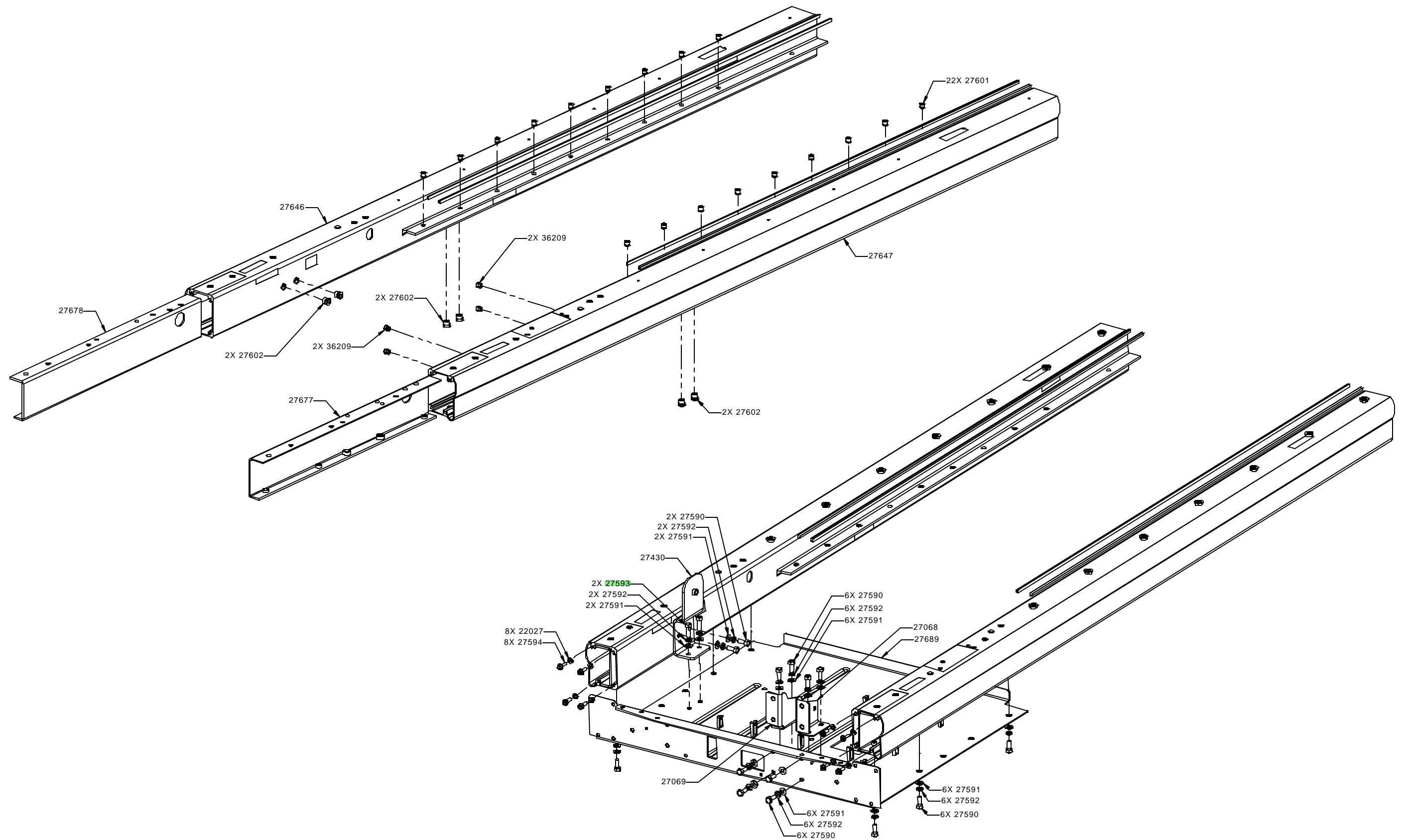

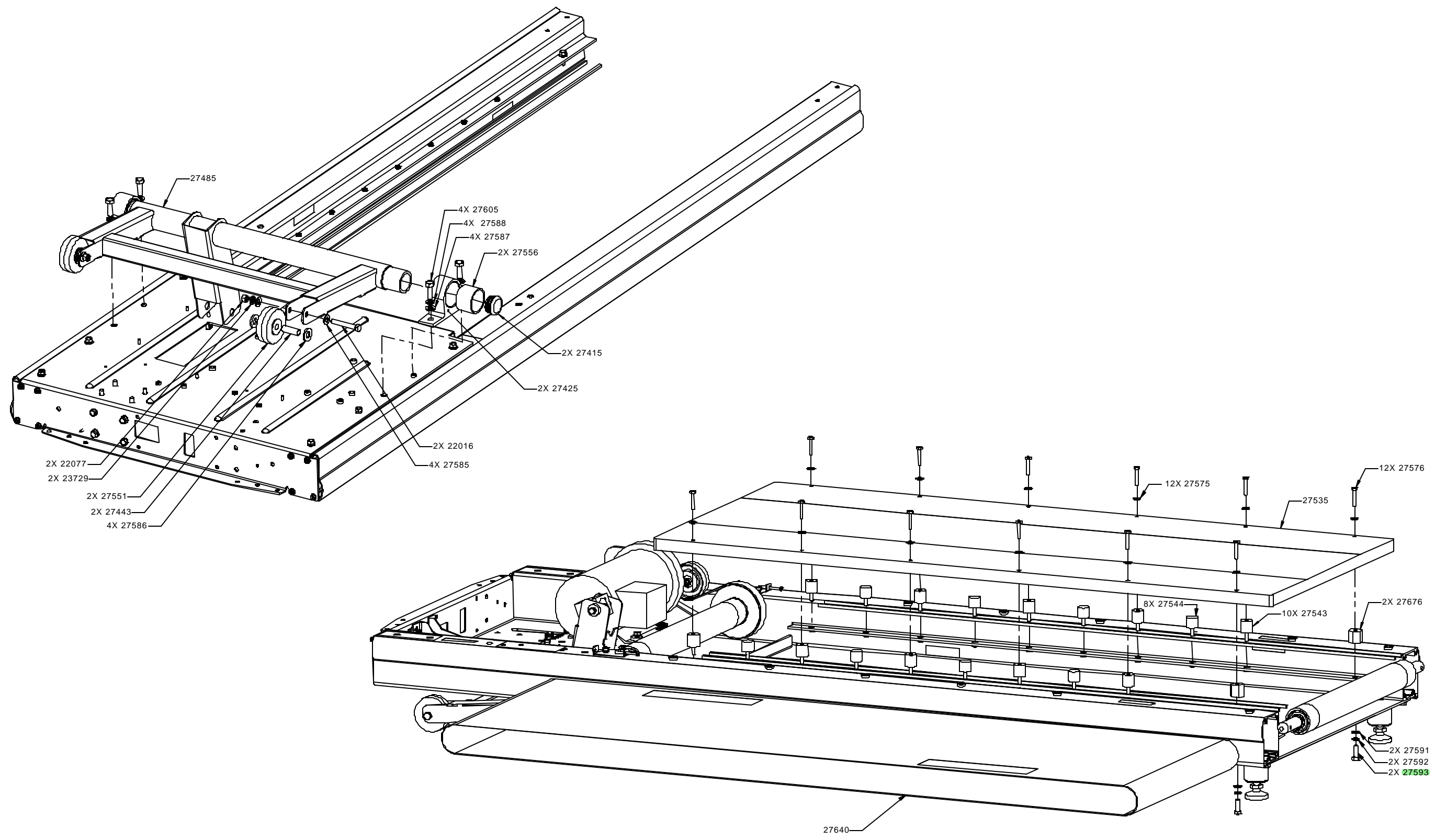

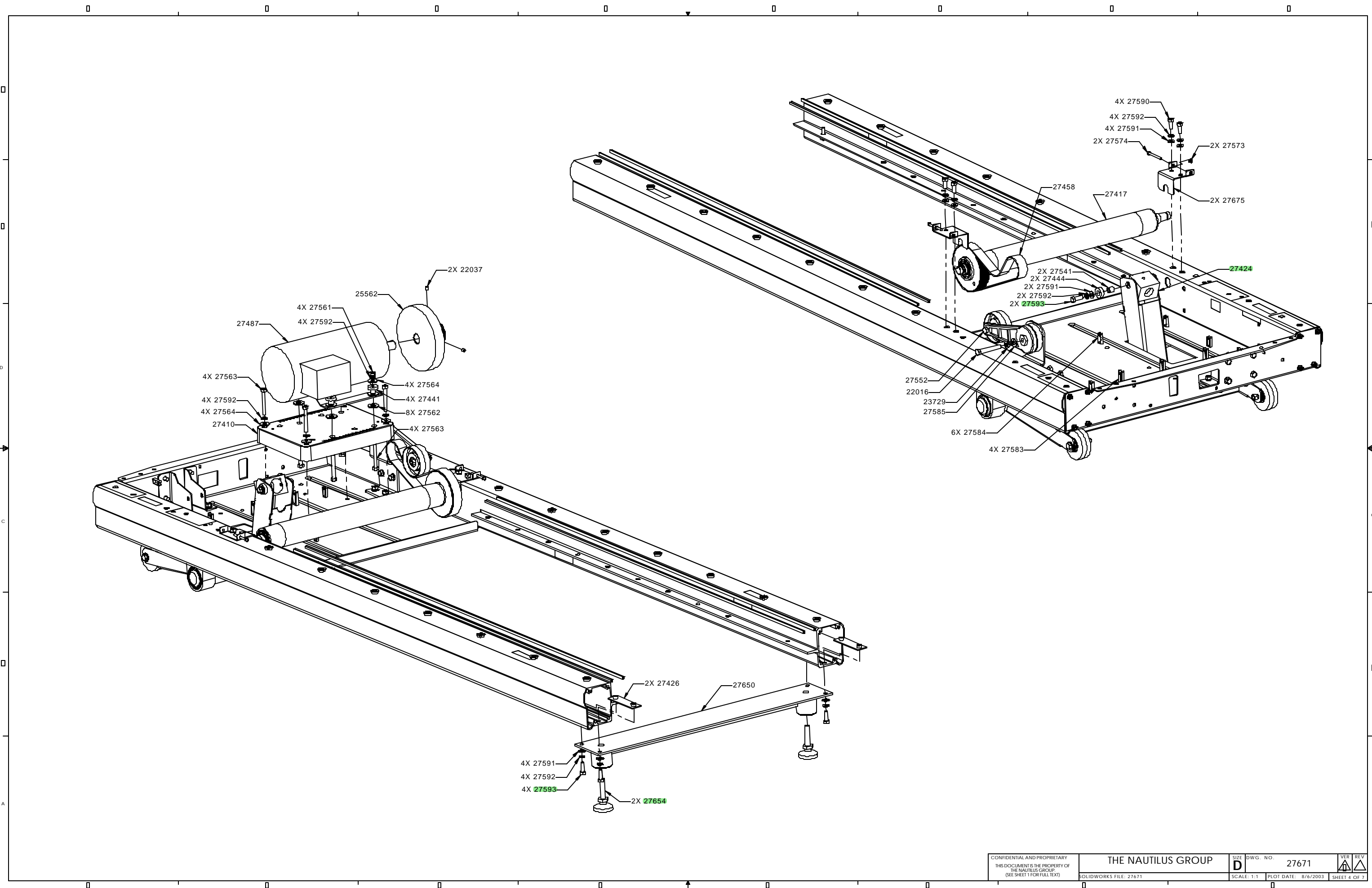

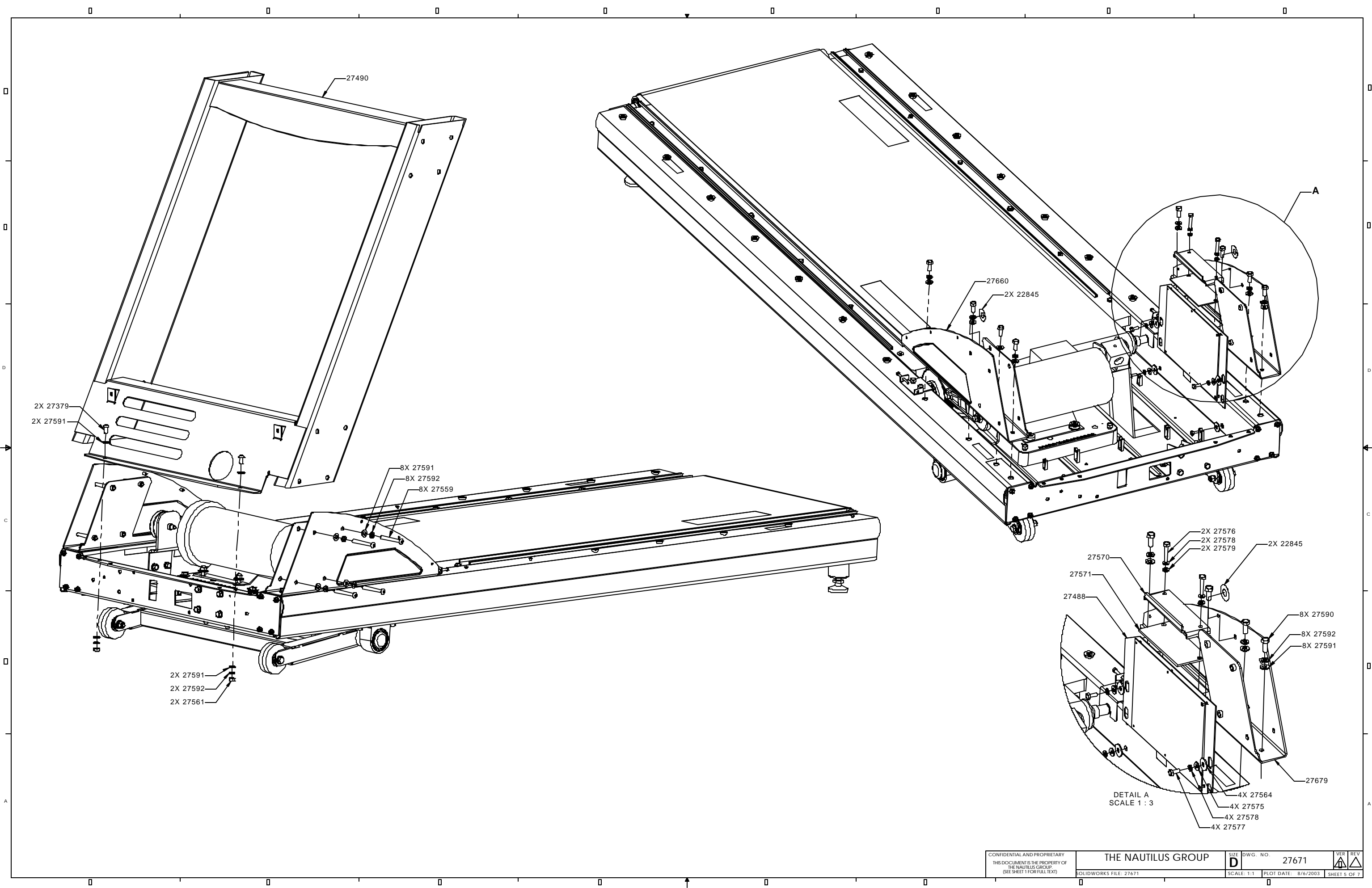

DETAIL A
SCALE 1 : 3

CONFIDENTIAL AND PROPRIETARY THIS DOCUMENT IS THE PROPERTY OF THE NAUTILUS GROUP. (SEE SHEET 1 FOR FULL TEXT)	THE NAUTILUS GROUP		SIZE DWG. NO. D 27671	VER REV
	SOLIDWORKS FILE: 27671		SCALE: 1:1 PLOT DATE: 8/6/2003	SHEET 5 OF 7

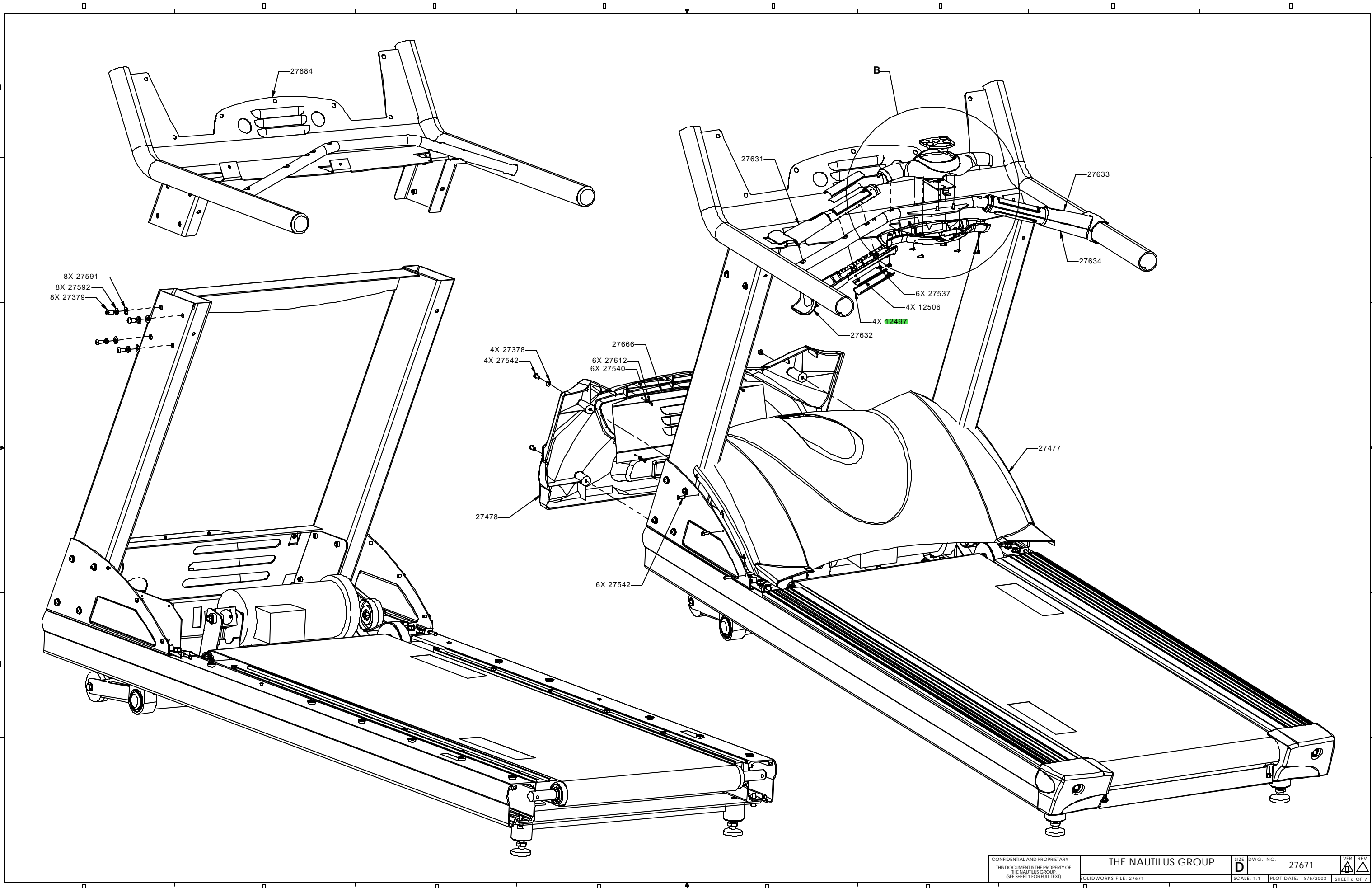

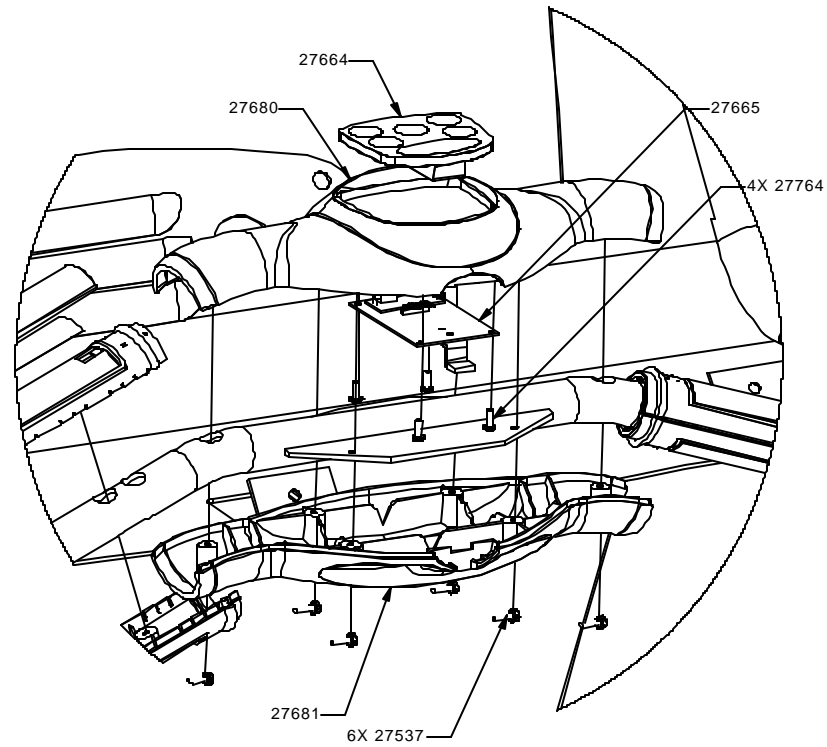

DETAIL B
SCALE 1 : 2

